

# Aquatech Unit Truck Benefit Diagram

**TRUCK SAFETY**

Trucks fitted with onboard scales, GPS Tracking and four cameras (front side and back) permanently recording.

**VACUUM PUMP**

Largest vacuum pump on any Combo Unit in Australia.

**WATER RECYCLER**

Able to recycle waste water and reuse for jetting lines to minimise downtime filling up water.

**360° VAC BOOM**

Able to pump pits in front of truck, whilst the truck acts as a traffic control unit.

**8" VAC BOOM**

Prevents blockages and able to suck up large debris.

**INFRARED**

Work zone delineation.

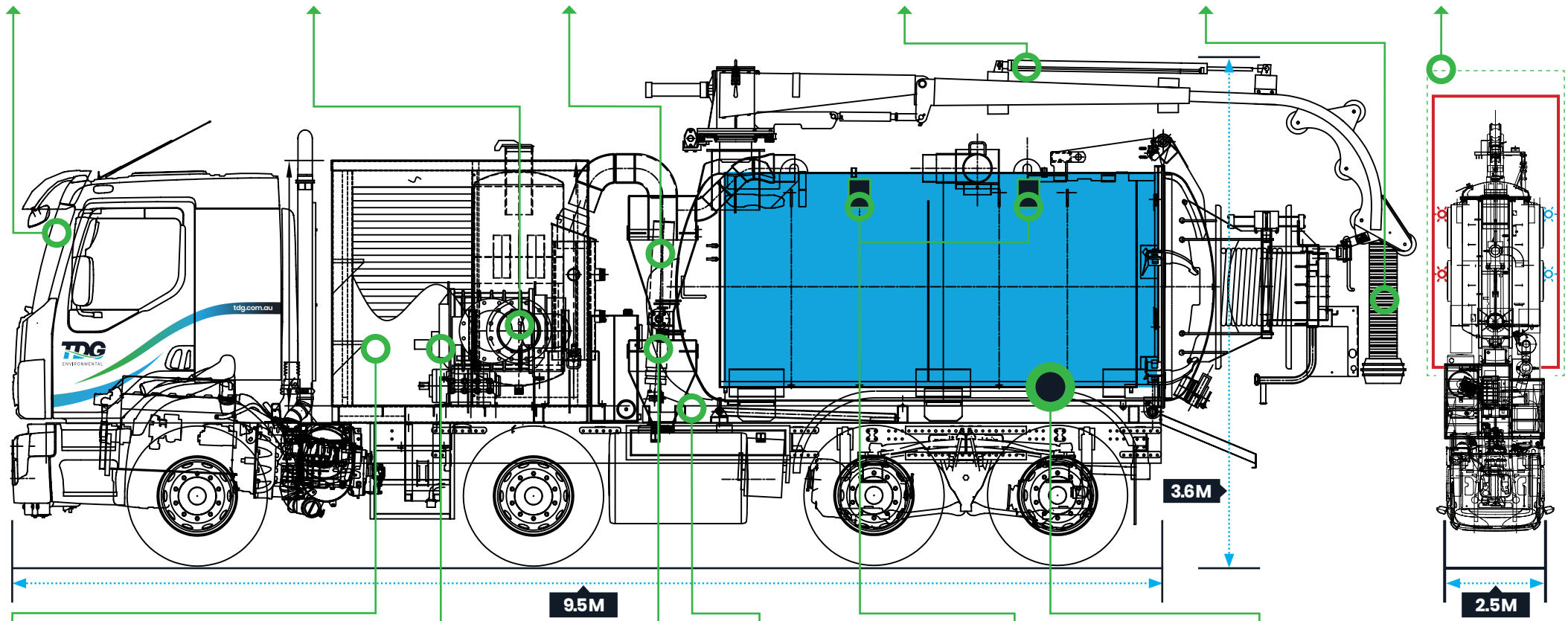

**ONBOARD HOSE REPAIRER**

Able to fix hoses without the need to call a hose repairer.

**POWER PLANT**

Fully enclosed power plant. Reduced noise under 80 decibels.

**PUMP-OFF SYSTEM**

Able to filter and pump off liquids to reduce waste disposal weight.

**NON-DESTRUCTIVE DIGGING**

With the same vacuum truck.

**INTERNAL FLUSH**

Able to wet loads if necessary to reduce air borne particles in a vacuum situation.

**DEBRIS TANK**

Heaviest legal payload in Australia. Reduces downtime from having to tip off-site.