

Kaiser Unit Truck Benefit Diagram

TRUCK SAFETY

Trucks fitted with onboard scales, GPS Tracking and Heavy Vehicle Navigation.

HOSE REEL

Unit is equipped with 220m of 1 1/4 inch for cleaning of large pipes and culverts.

VACUUM POWER

Powerful liquid ring vacuum pump allows vacuuming of debris at depths of over 20m.

QUIET OPERATION

Vacuum pump is housed in a sealed water tank greatly reducing operating noise. Perfect for residential areas and night works.

6" VAC CASSETTE

Capable of reaching 11.5m subsurface without extensions.

AUXILLARY HOSE REEL

Unit is equipped with 120m of 3/4 inch hose for cleaning of small diameter pipes and culverts.

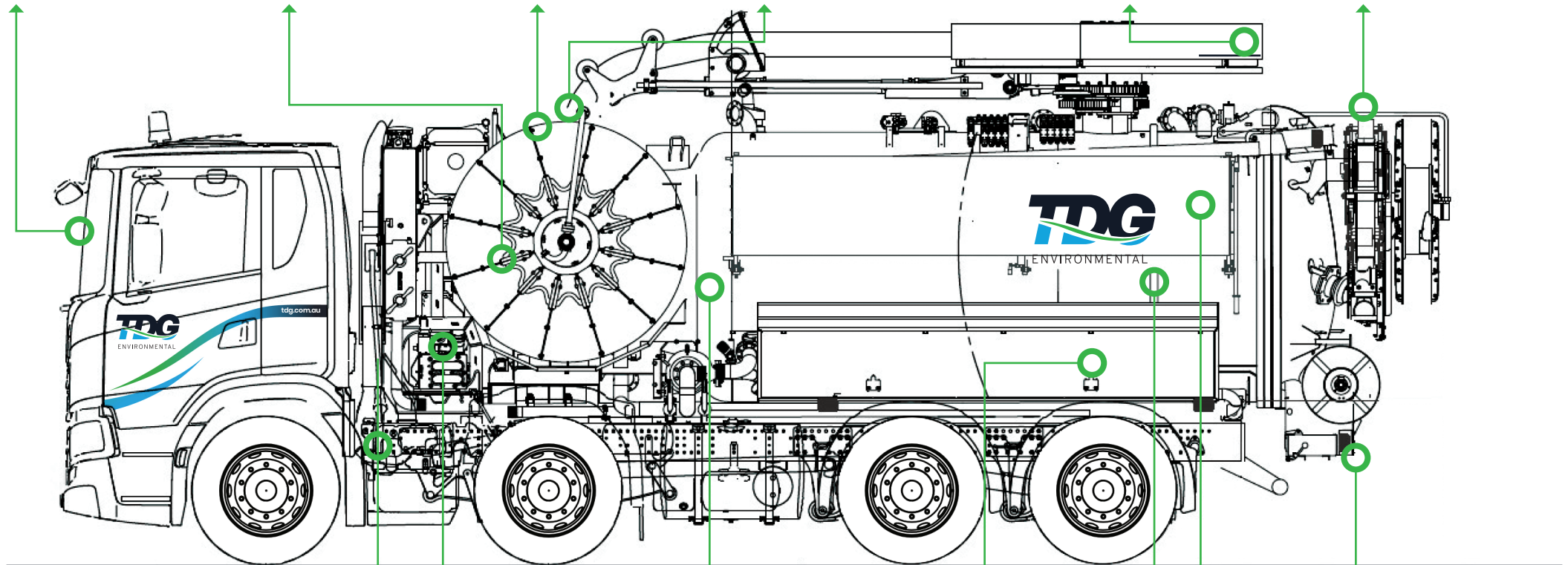

JETTING FLOW RATE

Maximum flow rate of 400 Liters Per Min at 2,900PSI.

WATER PUMP

Intelligent water pump allows for flow and pressure to be set independently, allowing precise cleaning of pipes and culverts.

ROTOMAX RECYCLING SYSTEM

Unique water pump and filtration system can recycle even the most heavily silted water from sewer and stormwater for further use during jetting.

CLEANING NOZZLES

Unit is equipped with an array of cleaning nozzles to suit all applications.

DEBRIS TANK

Variable debris capacity up to 10.6m³

ADDITIONAL HOSE

Unit is equipped with an additional hose, enabling vacuum works 30m from the truck.

HYDRO VACUUM EXCAVATION

Unit is capable of performing hydro excavation.